

TWIN SPOT



The Twin Spot is a light weight wall-mounted fixture that is designed to provide two hours of emergency power. It utilises 20W tungsten halogen lamps in the fully adjustable reflector heads. This IP65 weatherproof luminaire is suitable for providing emergency lighting in either open areas or packing aisles where mounting points are limited and access is difficult.

FEATURES

BODY

The body consists of gear housing and two floodlight heads mounted on top. The gear housing is manufactured from polycarbonate and finished in light grey. The two floodlight heads are moulded in black technopolymer.

LENS

The two floodlight heads each have a prismatic polycarbonate lens.

REFLECTOR

Mirror finish reflectors are provided in each floodlight head.

GEAR

Integral control gear is supplied in the gear housing.

INSTALLATION & MAINTENANCE

Maintenance-free sealed batteries are used to reduce maintenance requirements.

IP RATING

The protection rating is IP65.

SPECIAL FEATURES

The maintenance-free lead acid battery provides two hours of emergency operation. The fixture is non-maintained and supplied complete with two 20W tungsten halogen lamps.

MEASUREMENTS

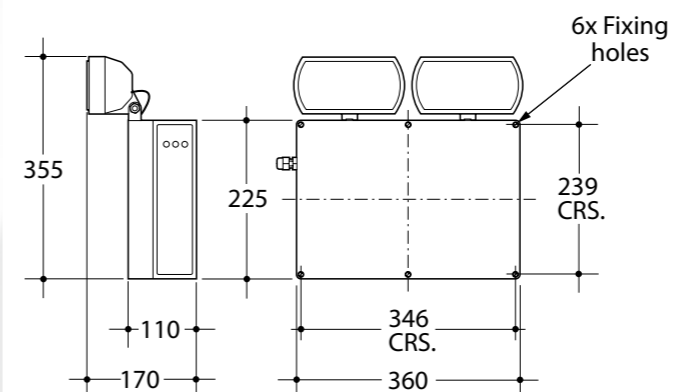

CODE	PRODUCT DESCRIPTION	WATTAGE	TYPE	LAMP	CONTROL GEAR	DIFFUSER/ LENS MATERIAL	LIGHT DISTRIBUTION	REFLECTOR TYPE
156165	TWIN SPOT HALOGEN EMERGENCY (Non-Maintained)	2 X 20W	TUNGSTEN HALOGEN 20W	NON-MAINTAINED	ATTACHED GEAR HOUSING WITH MAINTENANCE-FREE SEALED BATTERY	POLYCARBONATE LENS	WIDE BEAM	TWIN SYMMETRICAL - ADJUSTABLE

All fixtures supplied with lamp(s) and 240V(AUS) / 230V(NZ) 50Hz control gear and battery unless otherwise stated. Pictorial is representative only.



TWIN SPOT



Class I



IP65

