

METAL HALIDE CONTROL GEAR (FOR EYE "ACE" LAMPS)



EYE Lighting has a range of control gear products (IEC 60188) that are suitable for operating Metal Halide lamps with internal ignitors (such as EYE's range of Cera Arc Ace, Multi Super Ace, Multi Hi Ace and Clean Ace lamps). Versions are available in Gear Tray, Cast Box and Sturdigear configurations.

METAL HALIDE REQUIREMENTS

METAL HALIDE (MH) control gear is available in many types and configurations. The common MH type is simply a Mercury Vapour Reactor system with the addition of an ignitor to start the lamp. Some lamps, such as EYE "Ace" types feature an "internal ignitor" inside the lamp and so these types do not require an ignitor within the control gear.

GEAR TRAY TYPE

Gear Trays (GTS) are designed to be easily installed inside poles, walls, cabinets and other structures away from weather and other potential hazards. They do not have an IP rating. Gear Trays come in two basic footprints depending on the wattage see Figures 1 and 2 for the dimensions.

CAST BOX TYPE

Cast Box (CB) types are IP65 certified and are fully enclosed in a cast aluminium casing allowing fitment in exterior locations that are exposed to the weather. Cast boxes also come in two basic footprints depending on the wattage; see Figures 3 and 4 for the dimensions.

STURDIGEAR

Sturdigear types are like Cast Boxes but with the added protection of anti-vibration features allowing fitment in more demanding industrial locations or situations. Sturdigear is focused on higher wattage industrial situations so comes in one basic footprint; see Figure 5 for the dimensions.

WHY IS CONTROL GEAR NEEDED?

Metal Halide lamps with internal ignitors cannot function directly on mains voltage supply (eg, 240V 50Hz AC). Control gear is required to:

- ensure the lamp will continue to operate even though twice during each AC cycle the voltage is effectively zero;
- regulate and stabilise the current flow (this is because MH arc tubes have a "negative resistance" and without regulation will draw current until they self-destruct).

CAUTION

Control gear is designed to match the characteristics of particular lamp types and brands. The ballast (also known as a "choke") and ignitor requirements are different for many American, European and Japanese lamp types, and care is required to correctly match the lamp / choke / ignitor / supply voltage / combination. Mis-matched lamp / gear combinations can cause short life, reduced light output, colour shift, cycling and overheating of the components.

MEASUREMENTS

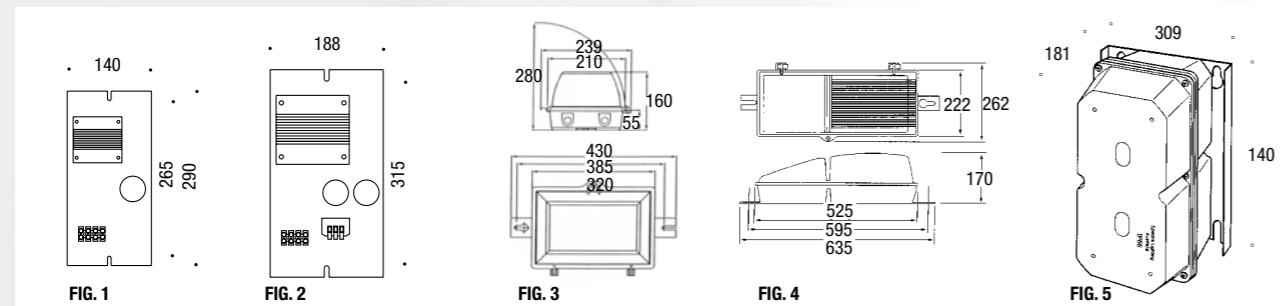

Wattage	Product Code	Description	Input Volts	Supply Current (at 0.9PF)		Lamp Values		Weight (kg)	Fig	Compatible Lamps
				Start Current	Run Current	Lamp Volts	Lamp Current			
125W	253500	H125 GTS	240	0.961	0.634	125	1.15	2.15	1	CM115FLS/EX
	253100	RH125 CB	240	0.961	0.634	125	1.15	4.75	3	MF125LE-BUH
250W	253505	H250 GTS	240	1.85	1.25	130	2.13	3.05	1	CM230LS/PRO CM230FLS/PRO M250LSH/U MF250LSH/U
	253105	RH250 CB	240	1.85	1.25	130	2.13	6.3	3	MT250LSH/BH MF250DL MT250DL
400W	253510	H400 GTS	240	3.15	1.98	135	3.25	3.75	1	CM360LS/PRO CM360FLS/PRO M400LSH/U MF400LSH/U
	253115	RH400 CB	240	3.15	1.98	135	3.25	7	3	MT400LSH/BH MF400DL MT400DL/BUD
1000W	253515	S940 GTS	240	6.35	4.54	145	7.5	9.2	2	M1000LE-BUH M1000LE-BD MF1000LE-BUH
		S940B GTS 415V	415	4.4	2.7	145	7.5	19.2	2	
	253135	RS940 CB	240	6.35	4.54	145	7.5	14	4	
		RS940B CB 415V	415	4.4	2.7	145	7.5	24.2	4	

METAL HALIDE CONTROL GEAR (MULTI METAL)



EYE Lighting has a range of metal halide control gear products (IEC 61167) that are suitable for operating EYE Multi Metal lamps. Versions are available in Gear Tray, Cast Box and Sturdigear configurations.

METAL HALIDE Multi Metal REQUIREMENTS

METAL HALIDE (MH) control gear is available in many types and configurations. For EYE's Multi Metal range of lamps both the Reactor ballast and the Constant Wattage types (CW for short) are used. Care must also be taken to ensure that a control gear's ignitor will match a specific lamp's requirements. Metal halide "ACE" lamps feature an "internal ignitor" and these types are not suitable with MH control gear including CW models (see previous section).

GEAR TRAY TYPE

Gear Trays (GTS) are designed to be easily installed inside poles, walls, cabinets and other structures away from weather and other potential hazards. They do not have an IP rating. Gear Trays come in two basic footprints depending on the wattage see Figures 1 and 2 for the dimensions.

CAST BOX TYPE

Cast Box (CB) types are IP65 certified and are fully enclosed in a cast aluminium casing allowing fitment in exterior locations that are exposed to the weather. Cast boxes also come in two basic footprints depending on the wattage; see Figures 3 and 4 for the dimensions.

STURDIGEAR

Sturdigear types are like Cast Boxes but with the added protection of anti-vibration features allowing fitment in more demanding industrial locations or situations. Sturdigear is focused on higher wattage industrial situations so comes in one basic footprint; see Figure 5 for the dimensions.

WHY IS CONTROL GEAR NEEDED?

Metal Halide lamps cannot function directly on mains voltage supply (eg, 240V 50Hz AC). Control gear is required to:

- ignite the lamp using a specific voltage spike higher than the normal mains voltage;
- ensure the lamp will continue to operate even though twice during each AC cycle the voltage is effectively zero;
- regulate and stabilise the current flow (this is because MH arc tubes have a "negative resistance" and without regulation will draw current until they self-destruct).

CAUTION

Control gear is designed to match the characteristics of particular lamp types and brands. The ballast (also known as a "choke") and ignitor requirements are different for many American, European and Japanese lamp types, and care is required to correctly match the lamp / choke / ignitor / supply voltage / combination. Mis-matched lamp / gear combinations can cause short life, reduced light output, colour shift, cycling and overheating of the components.

Care must be exercised with the correct selection of cable between the output of the remote control gear and the lamp. The ignitor pulses required to start the lamp can be attenuated by the self capacitance of the cable and the capacitance between the conductors and an earthed surface. Self capacitance in most installations is between 70-100 PF/m. It is good practice to locate the ignitor as close as possible to the lamp.

MEASUREMENTS

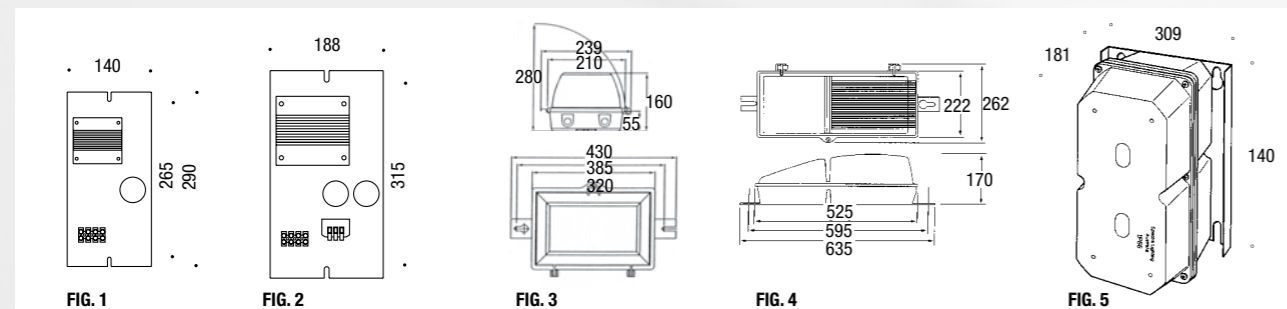

175W

Product Code	Description	Input Volts	Supply Current (at 0.9PF)		Lamp Values		Weight (kg)	Fig	Compatible Lamps
			Start Current	Run Current	Lamp Volts	Lamp Current			
-	M175 GTS	240	1.42	0.88	130	1.5	2.8	1	M175X/U MF175X/U
-	RM175 CB	240	1.42	0.88	130	1.5	5.75	3	

250W

Product Code	Description	Input Volts	Supply Current (at 0.9PF)		Lamp Values		Weight (kg)	Fig	Compatible Lamps
			Start Current	Run Current	Lamp Volts	Lamp Current			
253530	M250 GTS	240	1.85	1.25	130	2.13	3.6	1	M250X/U MF250X/U MT250-BH
253155	RM250 CB	240	1.85	1.25	130	2.13	6.55	3	

400W

Product Code	Description	Input Volts	Supply Current (at 0.9PF)		Lamp Values		Weight (kg)	Fig	Compatible Lamps
			Start Current	Run Current	Lamp Volts	Lamp Current			
253535	M400 GTS	240	3.15	1.98	135	3.25	4.3	1	M400X/U MF400X/U MT400-BH MRF400BU MT400SX/HOR M400SX/BU MF400SX/BU
253160	RM400 CB	240	3.15	1.98	135	3.25	7.55	3	
251220	STURDIGEAR 400W MH	240	3.15	1.98	135	3.25	12.8	5	

1000W

Product Code	Description	Input Volts	Supply Current (at 0.9PF)		Lamp Values		Weight (kg)	Fig	Compatible Lamps
			Start Current	Run Current	Lamp Volts	Lamp Current			
253540	M1000(A) GTS	240	6.31	4.95	145	7.5	9.55	2	MT1000A-BH/67
253165	RM1000(A) CB	240	6.31	4.95	145	7.5	14.55	4	
253545	M1000(B) GTS	240	3.0	4.90	250	4.5	15	2	M1000BX/U MF1000BX/U M1000BSX/BU MF1000BSX/BU
253550	M1000(B) B GTS	415	1.73	2.83	250	4.5	15	2	
253170	RM1000 CB-CW	240	3.0	4.90	250	4.5	20	4	MT1000B-BH MT1000B-BH-SRL
253175	RM1000 CB B	415	1.73	2.83	250	4.5	25	4	
251235	STURDIGEAR 1KW MH CW	240	3.0	4.90	250	4.5	24.6	5	

2000W

Product Code	Description	Input Volts	Supply Current (at 0.9PF)		Lamp Values		Weight (kg)	Fig	Compatible Lamps
			Start Current	Run Current	Lamp Volts	Lamp Current			
-	M2000(B) GTS	415	7.7	5.5	245	8.8	16	2	MT2000(B)-BH/L-T
253180	RM2000(B) CB	415	7.7	5.5	245	8.8	21	4	
253560	M2000S(B) GTS	415	6.9	5.6	205	11.3	16	2	HQI-TS/N/L

